

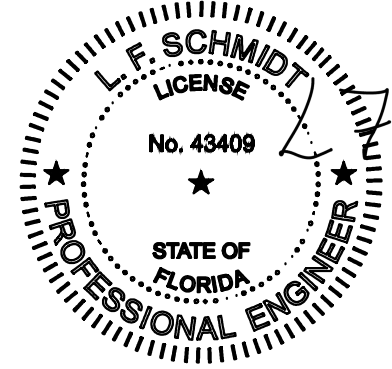

250 Staunton Turnpike, Parkersburg, WV 26104

# 500 Series Vinyl Single Hung Window w/ Nailing Fin "NON-IMPACT"

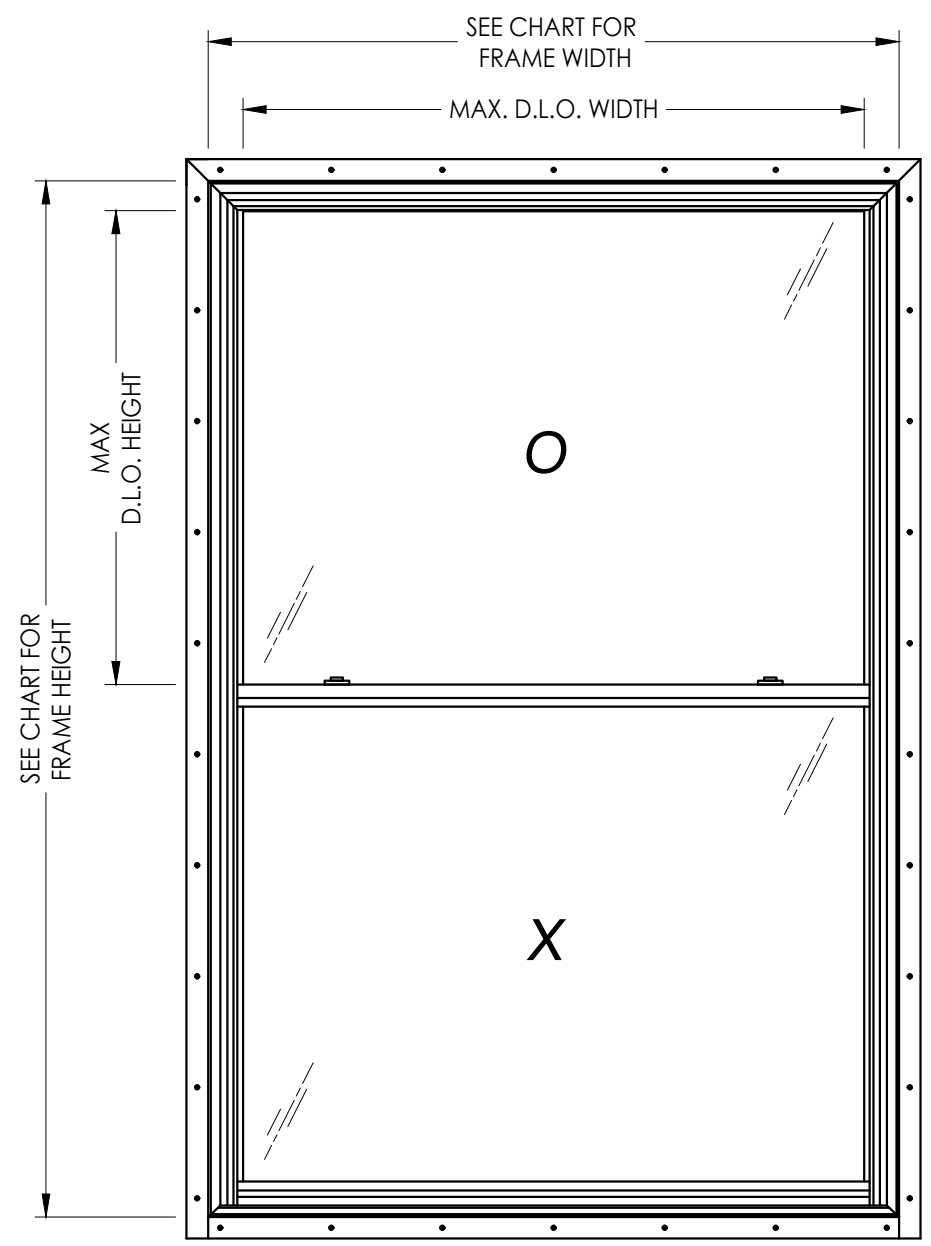

*Shild*

This item has been digitally signed and sealed by L. F. Schmidt, P.E. on the date adjacent to the seal. Printed copies of this document are not considered signed and sealed and the signature must be verified on any electronic copies.

THIS PRODUCT APPROVAL IS VALID ONLY FOR THE STATE OF FLORIDA

Documents Prepared By:  
Lyndon F. Schmidt  
P.E. No. 43409

*RW*  
BUILDING CONSULTANTS, INC.  
P.O. Box 230, Vairico, FL 33595  
Phone No.: 813.659.9197  
FBPE Registry No. 9813

### GENERAL NOTES

1. This product has been evaluated and is in compliance with the 8th Edition (2023) Florida Building Code (FBC) structural requirements excluding the "High Velocity Hurricane Zone" (HVHZ).
2. Product anchors shall be as listed and spaced as shown on details. Anchor embedment to base material shall be beyond wall dressing or stucco.
3. When used in areas requiring wind borne debris protection this product is required to be protected with an impact resistant covering that complies with FBC Sections 1609.1.2 & R301.2.1.2.
4. Site conditions that deviate from the details of this drawing require further engineering analysis by a licensed engineer or registered architect.

TABLE OF CONTENTS	
SHEET#	DESCRIPTION
1	Typical elevations, design pressures and general notes
2	Horizontal cross sections
3	Vertical cross sections
4	Buck and frame anchoring
5	Bill of materials, components & glazing details

MAX. FRAME DIMENSION	MAX. FIXED D.L.O. DIMENSION	GLASS TYPE	DESIGN PRESSURE (PSF)		BOTTOM RAIL REINFORCEMENT REQUIRED
			POSITIVE	NEGATIVE	
36.0" X 80.0"	31.5" X 36.75"	G1	+50.0	-50.0	YES
48.0" X 72.0"	43.5" X 32.75"	G2	+50.0	-50.0	YES
48.0" X 96.0"	43.5" X 55"	G2	+40.0	-40.0	NO
40.0" X 84.0"	35.5" X 38.5"	G2	+35.0	-35.0	YES
52.0" X 77.0"	47.5" X 35.25"	G2	+35.0	-35.0	YES
36.0" X 96.0"	31.5" X 44.75"	G2	+30.0	-30.0	NO
48.0" X 96.0"	43.5" X 44.75"	G3	+30.0	-30.0	NO

PRODUCT: 500 SERIES Vinyl Single Hung Window  
PART OR ASSEMBLY: TYPICAL ELEVATION, DESIGN PRESSURES & GENERAL NOTES

NO.	DATE	BY	REVISIONS
4	7/06/23	LFS	UPDATE TO 8TH ED. (2023) FBC
3	7/02/20	LFS	UPDATE TO 7TH ED. (2020) FBC
2	6/01/17	JK	UPDATE TO 6TH ED. (2017) FBC
1	1/12/16	LFS	ADDED FRAME SIZES

DATE: 2/11/15  
SCALE: N.T.S.  
DWG. BY: JK  
CHK. BY: LFS  
DRAWING NO.: FL-17088.4  
SHEET 1 OF 5

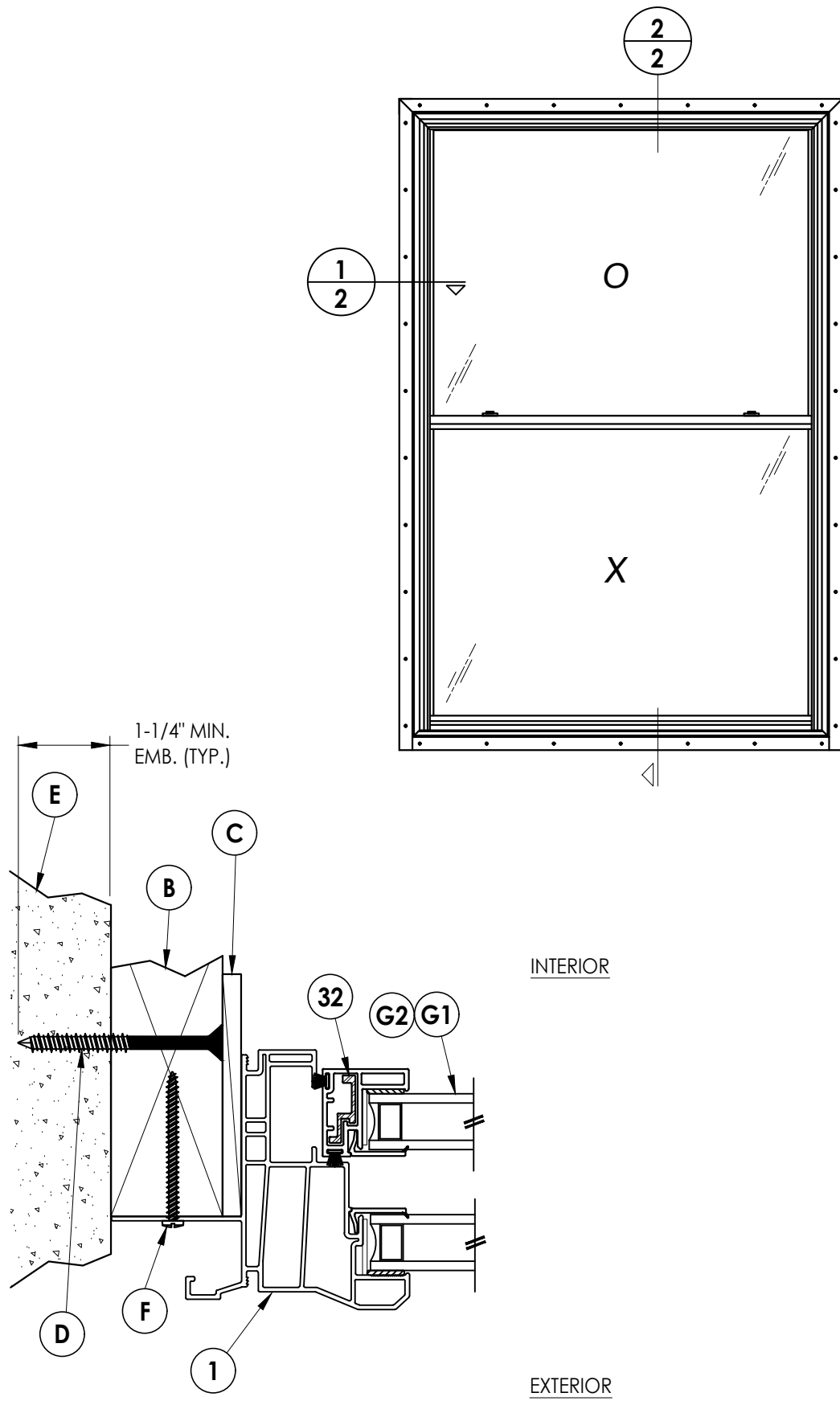

**1 HORIZONTAL CROSS SECTION**  
 2 Shown w/ 2X buck

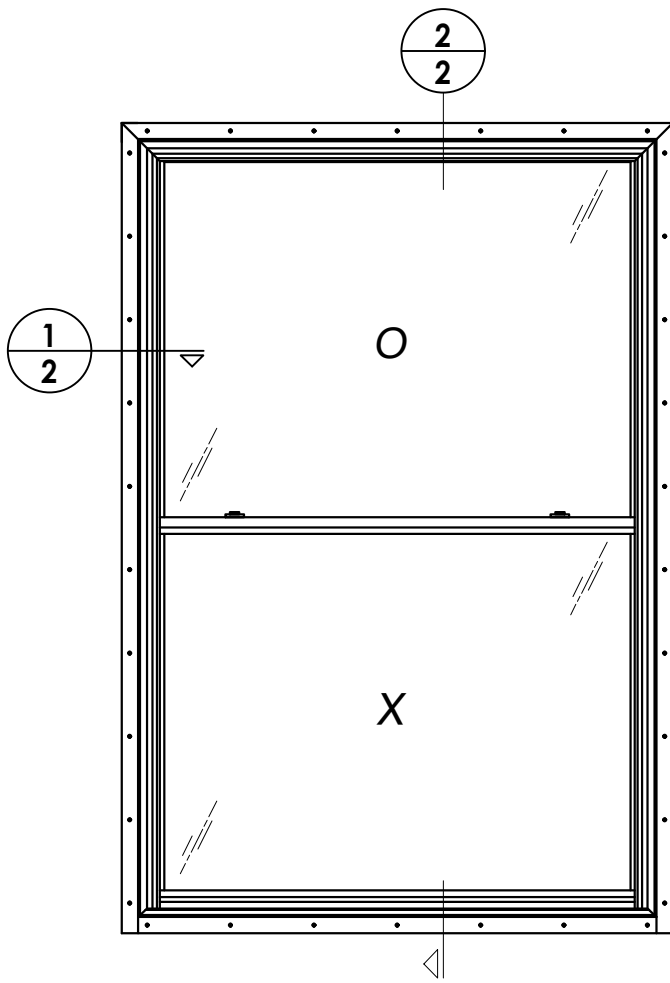

INTERIOR  
 EXTERIOR

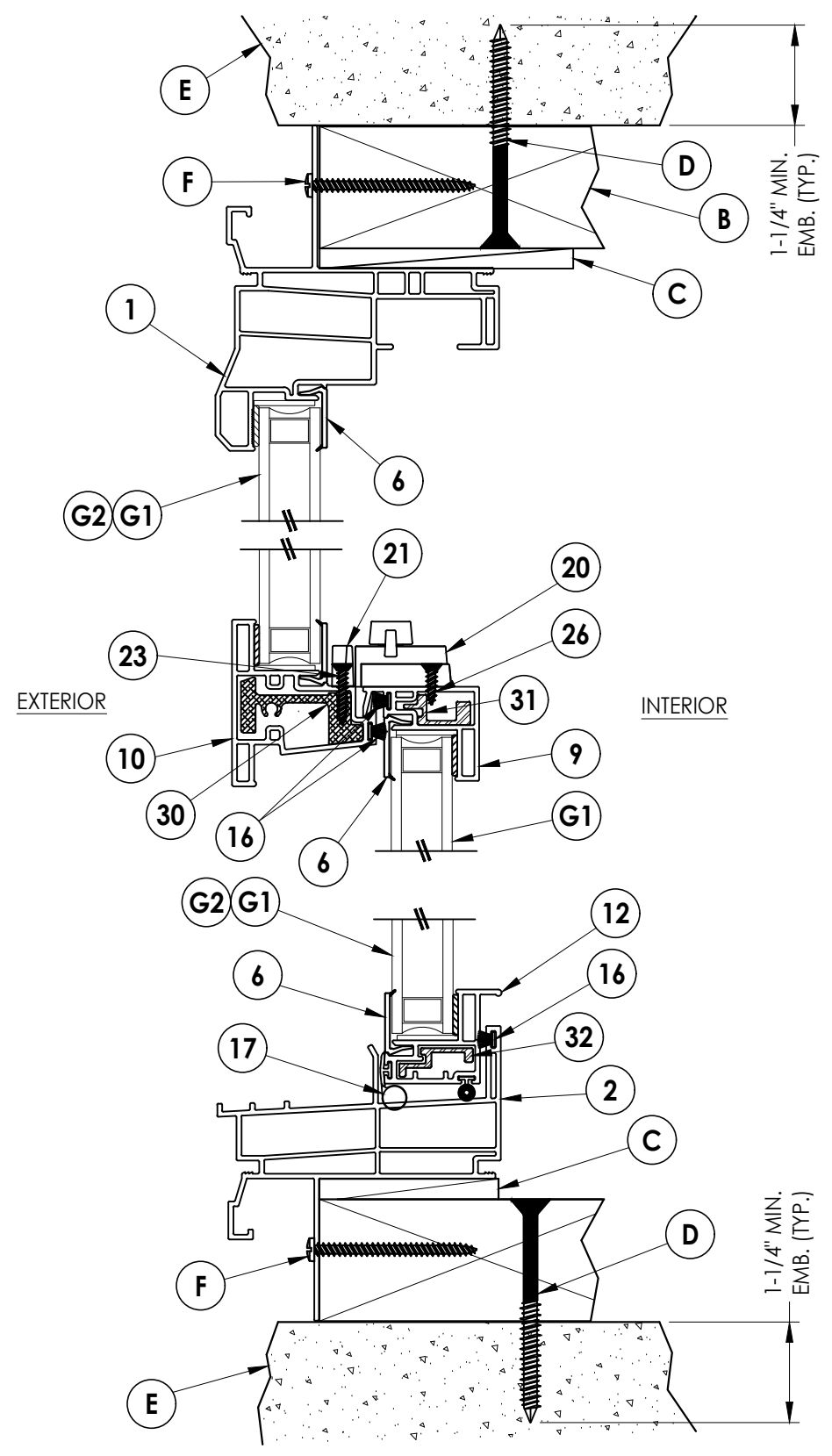

**2 HORIZONTAL CROSS SECTION**  
 2 Shown w/ 2X buck

Documents Prepared By: Lyndon F. Schmidt P.E. No. 43409		500 SERIES Vinyl Single Hung Window	
BUILDING CONSULTANTS, INC. P.O. Box 230, Vairico, FL 33595 Phone No.: 813.659.9197 FBPE Registry No. 9813		PART OR ASSEMBLY: HORIZONTAL CROSS SECTIONS	
DATE:	2/11/15	NO.	DATE
SCALE:	N.T.S.	NO.	DATE
DWG. BY:	JK	NO.	DATE
CHK. BY:	LFS	NO.	DATE
DRAWING NO.:	FL-17088.4	NO.	DATE
SHEET	2	OF	5

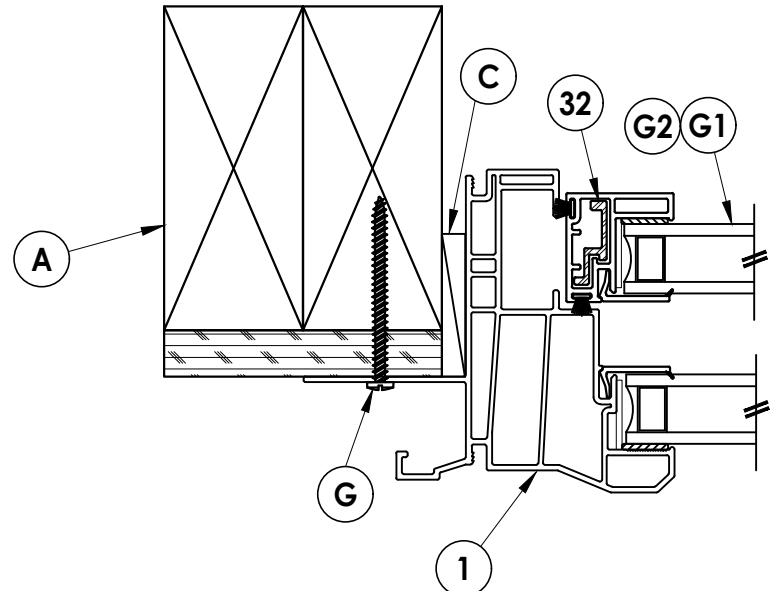
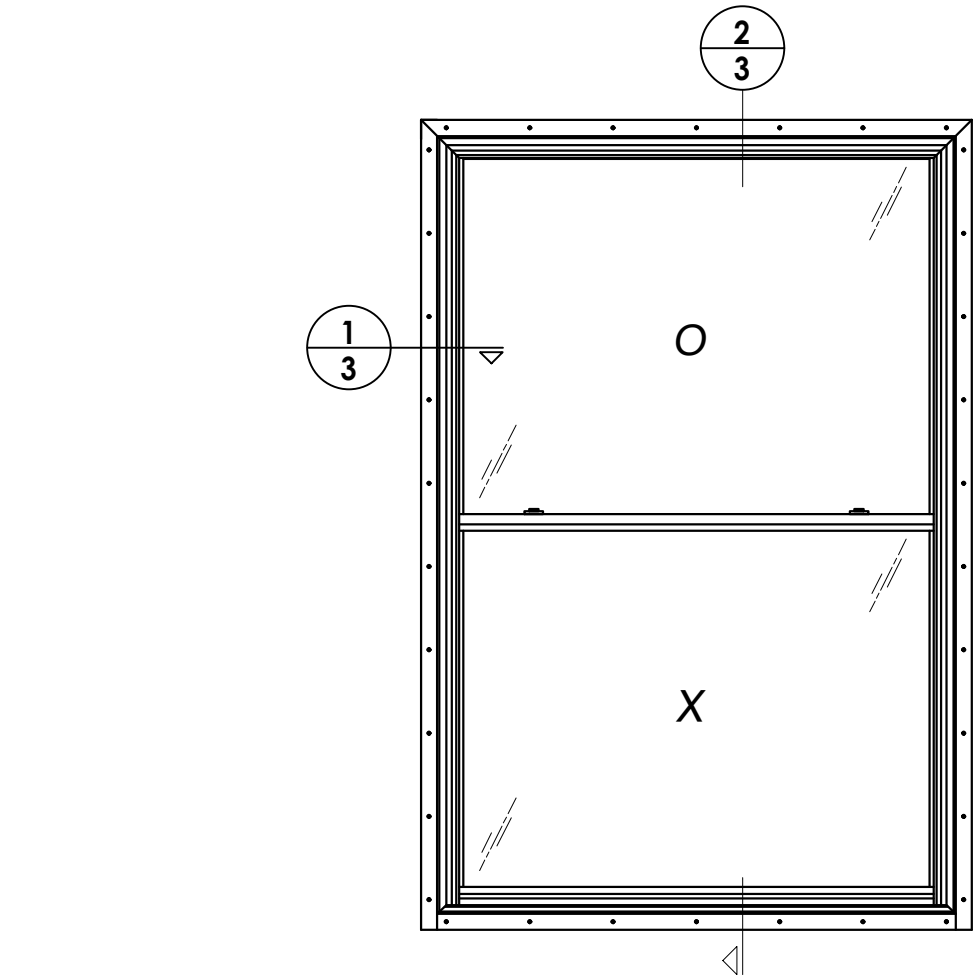

**1 HORIZONTAL CROSS SECTION**  
**3** Shown w/ 2X framing

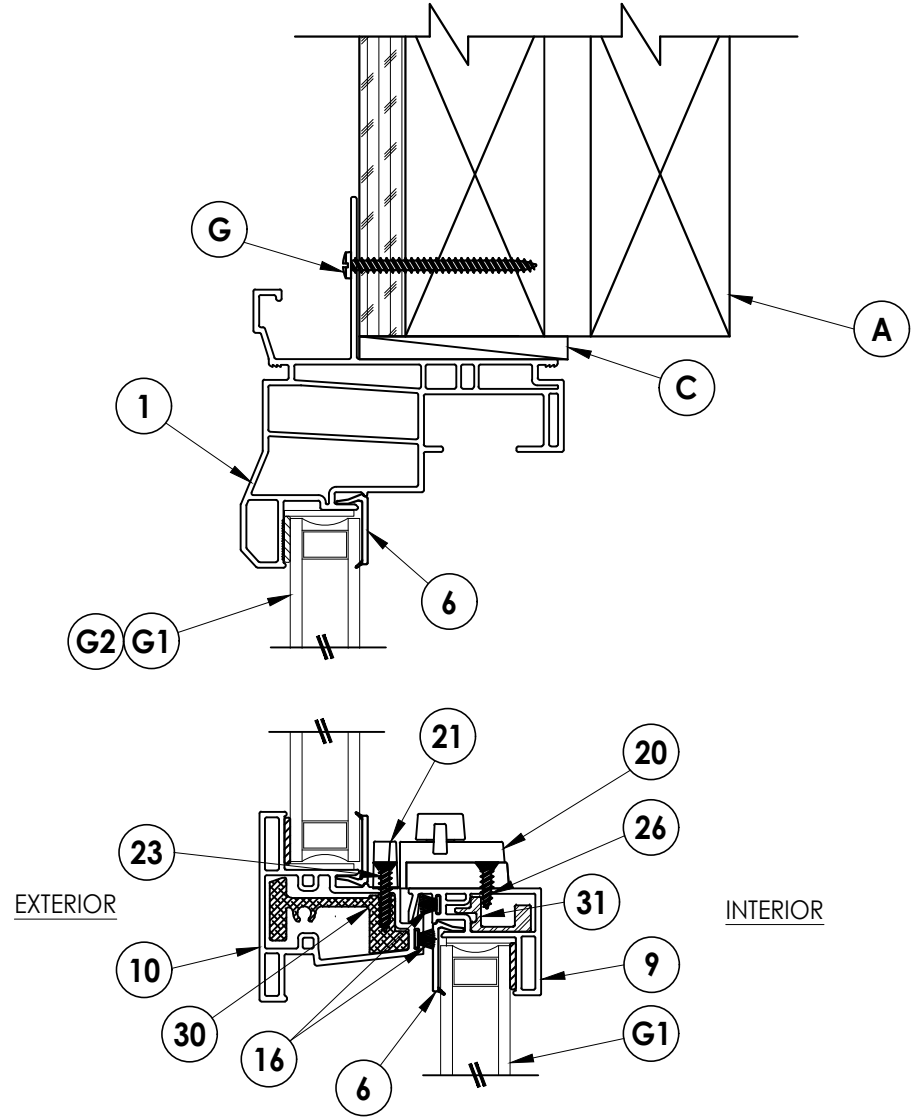

**2 HORIZONTAL CROSS SECTION**  
**3** Shown w/ 2X framing

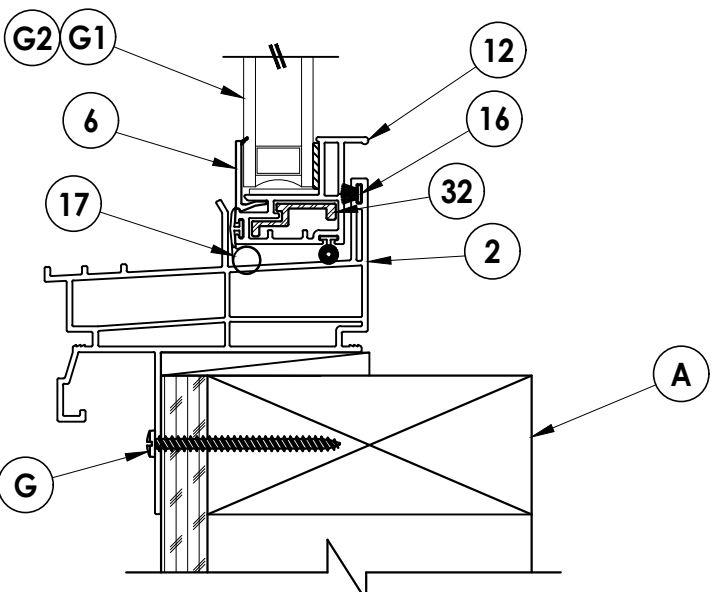

Documents Prepared By:  
 Lyndon F. Schmidt  
 P.E. No. 43409

**RW** BUILDING CONSULTANTS, INC.  
 P.O. Box 230, Vairico, FL 33595  
 Phone No.: 813.659.9197  
 FBPE Registry No. 9813

PRODUCT: 500 SERIES Vinyl Single Hung Window  
 PART OR ASSEMBLY: VERTICAL CROSS SECTIONS

NO.	DATE	REVISIONS
4	7/06/23	UPDATE TO 8TH ED. (2023) FBC LFS
3	7/02/20	UPDATE TO 7TH ED. (2020) FBC LFS
2	6/01/17	UPDATE TO 6TH ED. (2017) FBC JK
1	1/12/16	ADDED FRAME SIZES LFS

DATE: 2/11/15  
 SCALE: N.T.S.  
 DWG. BY: JK  
 CHK. BY: LFS  
 DRAWING NO.: FL-17088.4  
 SHEET 3 OF 5

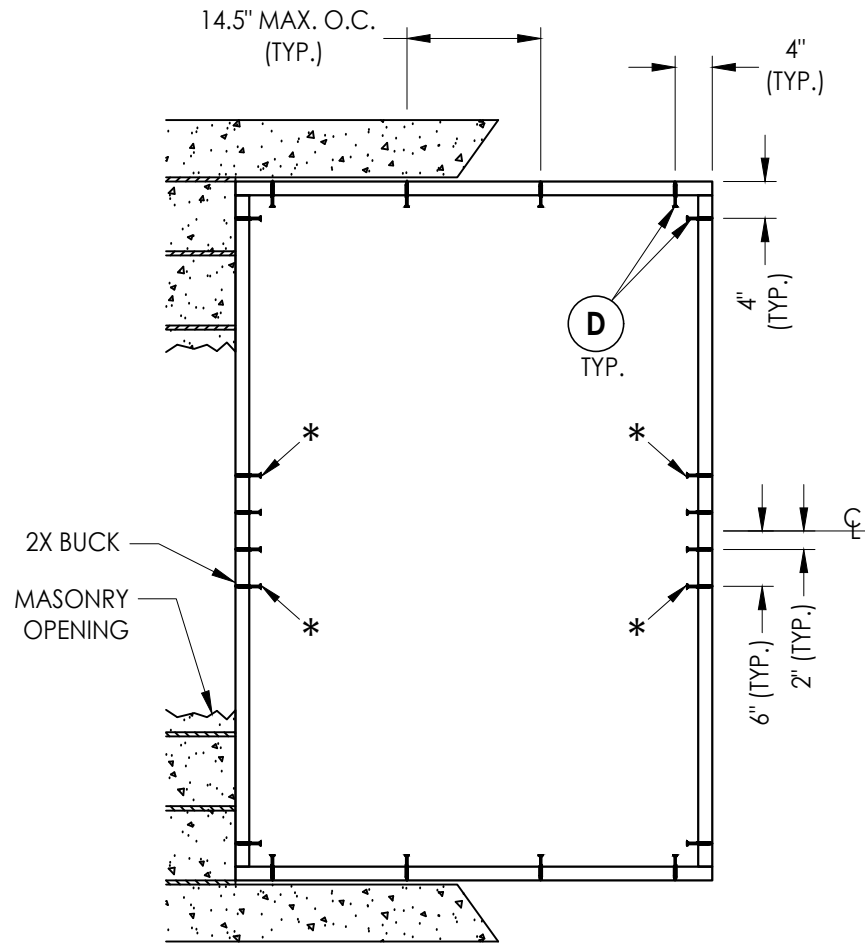

**BUCK ANCHORING**

\* Anchors indicated are required for Design Pressure > 45 psf only.

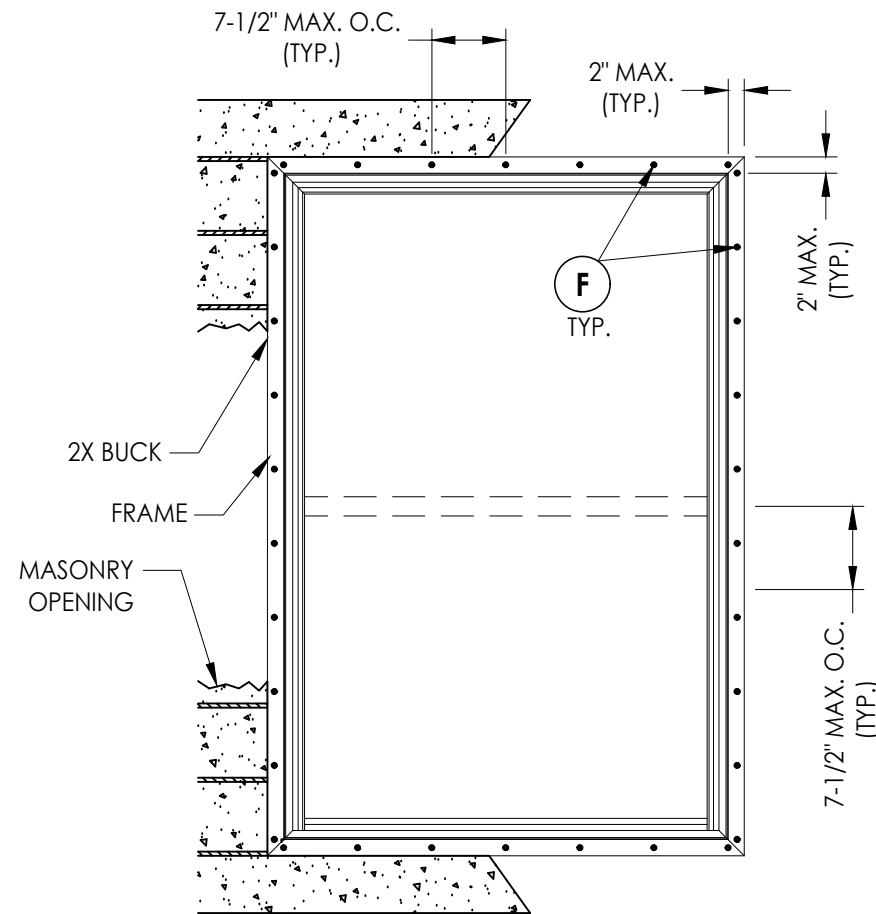

**FRAME ANCHORING**

2X Buck

2X FRAMING TO BE DESIGNED BY THE ENGINEER OR ARCHITECT OF RECORD BASED ON WIND LOADS AND THE CLADDING BEING USED.

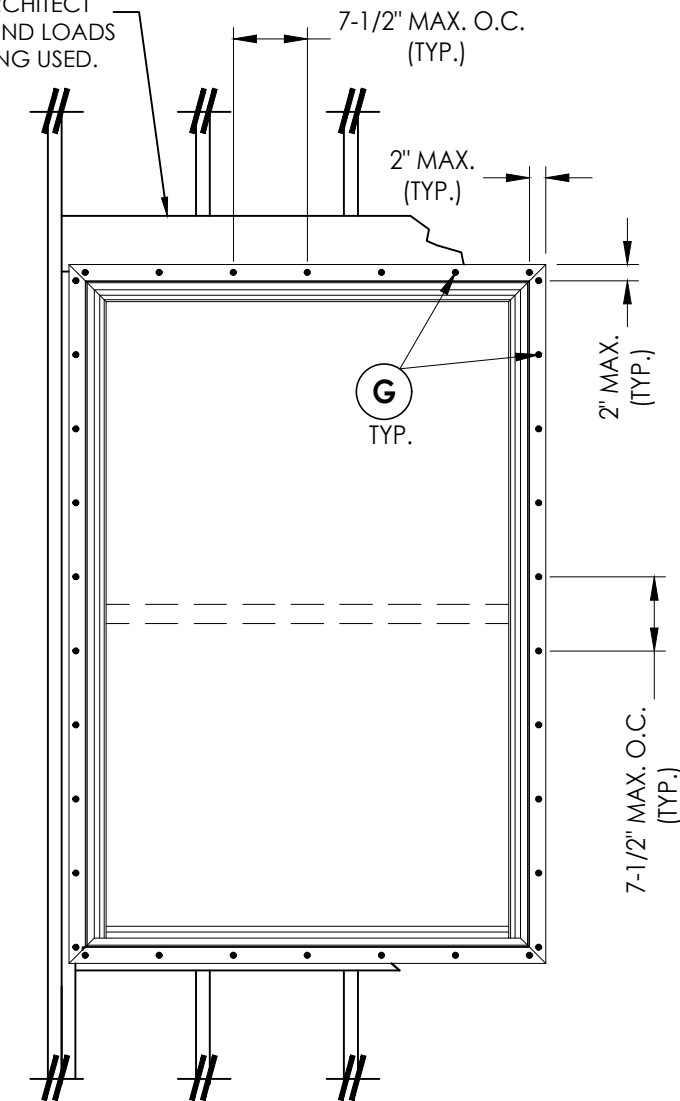

**FRAME ANCHORING**

2x stud construction

**CONCRETE ANCHOR NOTES:**

1. Concrete anchor locations at the corners may be adjusted to maintain the min. edge distance to mortar joints.
2. Concrete anchor locations noted as "MAX. ON CENTER" must be adjusted to maintain the min. edge distance to mortar joints, additional concrete anchors may be required to ensure the "MAX. ON CENTER" dimension are not exceeded.
3. Concrete anchor table:

ANCHOR TYPE	ANCHOR SIZE	MIN. EMBEDMENT	MIN. CLEARANCE TO MASONRY EDGE	MIN. CLEARANCE TO ADJACENT ANCHOR
ITW TAPCON®	1/4"	1-1/4"	2"	4"
DeWALT ULTRACON®	1/4"	1-1/4"	1"	4"

**WOOD SCREW INSTALLATION NOTES:**

1. Maintain a minimum 5/8" edge distance, 1" end distance, & 1" o.c. spacing of wood screws to prevent the splitting of wood.

Documents Prepared By:  
Lyndon F. Schmidt  
P.E. No. 43409

**RW** BUILDING CONSULTANTS, INC.  
P.O. Box 230, Vairico, FL 33595  
Phone No.: 813.659.9197  
FBPE Registry No. 9813

PRODUCT: 500 SERIES Vinyl Single Hung Window  
PART OR ASSEMBLY: BUCK AND FRAME ANCHORING

NO.	DATE	REVISIONS
4	7/06/23	UPDATE TO 8TH ED. (2023) FBC LFS
3	7/02/20	UPDATE TO 7TH ED. (2020) FBC LFS
2	6/01/17	UPDATE TO 6TH ED. (2017) FBC JK
1	1/12/16	ADDED FRAME SIZES LFS

DATE: 2/11/15  
SCALE: N.T.S.  
DWG. BY: JK  
CHK. BY: LFS  
DRAWING NO.: FL-17088.4  
SHEET 4 OF 5

**BILL OF MATERIALS**

ITEM #	DESCRIPTION	MATERIAL
A	2X FRAMING SG >= 0.42	WOOD
B	2X BUCK SG >= 0.42	WOOD
C	1/4" MAX. SHIM SPACE	-
D	1/4" X 2-3/4" PFH DeWALT OR ITW CONCRETE SCREW	STEEL
E	MASONRY - 3,000 PSI MIN. CONCRETE CONFORMING TO ACI 301 OR HOLLOW BLOCK CONFORMING TO ASTM C90	CONCRETE
F	#8 X 2" PFH WOOD SCREW (1-3/4" MIN. EMBEDMENT)	STEEL
G	#8 X 2-1/2" PFH WOOD SCREW (1-3/4" MIN. EMBEDMENT)	STEEL
1	FRAME HEAD AND JAMB*	PVC
2	SILL*	PVC
5	SASH STILE*	PVC
6	GLAZING BEAD*	PVC
9	LOCK RAIL LOWER SASH*	PVC
10	STAYBAR*	PVC
12	BOTTOM RAIL LOWER SASH*	PVC
16	WEATHERSTRIP ULTRA FAB .270 PILE - 270 -1875B	-
17	WEATHERSTRIP SILLBULB (AMESBURY 32690)	-
20	LOCK 8513 / 8845 LAWRENCE	PVC
21	KEEPER 2700 - 214 LAWRENCE	PVC
23	#6 X 3/4" PFH (VINYL LOCK SCREWS)	STEEL
24	SASH TILT LATCH - ASHLAND	PVC
26	#6 X 1/2" PFH (VINYL LOCK SCREWS)	STEEL
30	REINFORCEMENT (FIXED MEETING RAIL) ALUM. 6063-T6	ALUM
31	REINFORCEMENT (MEETING RAIL) ALUM. 6063-T6	ALUM
32	REINFORCEMENT (SASH STILES, BTM. RAIL) ALUM. 6063-T6	ALUM

\* THE APPROVED WHITE RIGID PVC EXTERIOR EXTRUSIONS FOR WINDOWS ARE TO BE PRODUCED BY EXTRUDERS LICENSEES IN "AAMA CERTIFICATION PROGRAMS FOR RIGID PVC EXTRUSIONS".

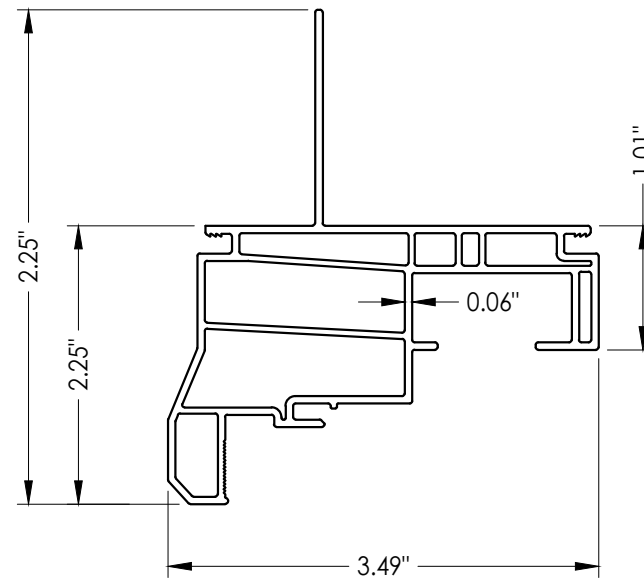

**1 FRAME HEAD & JAMB**

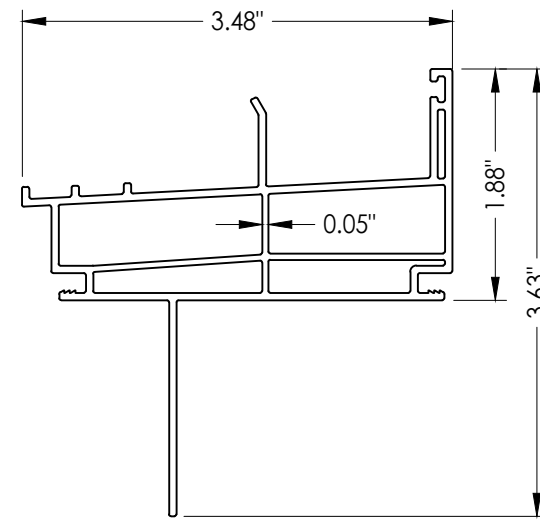

**2 SILL**

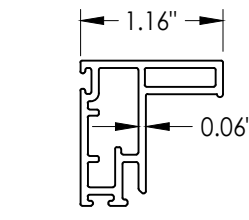

**5 SASH STILE**

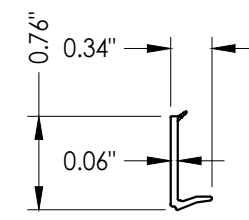

**6 GLAZING BEAD**

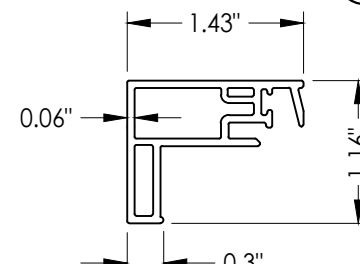

**9 LOCK RAIL**  
Lower Sash

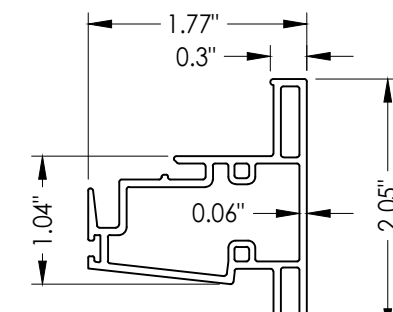

**10 STAYBAR**

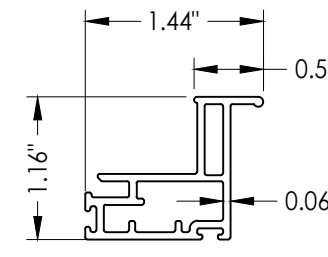

**12 BOTTOM RAIL**  
Lower Sash

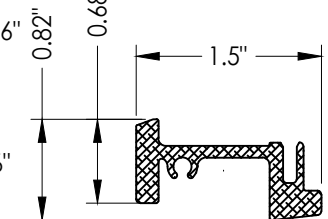

**30 REINFORCEMENT**  
FIXED MEETING RAIL

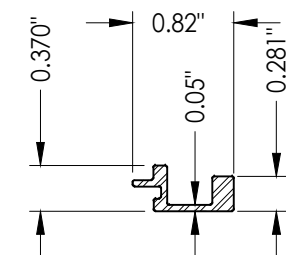

**31 REINFORCEMENT**  
MEETING RAIL

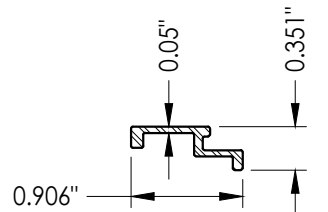

**32 REINFORCEMENT**  
SASH STILE/BTM. RAIL

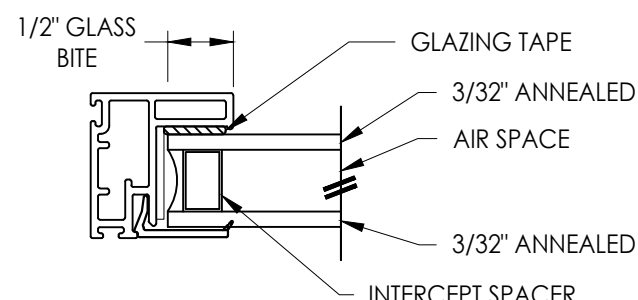

**G1 GLAZING DETAIL**

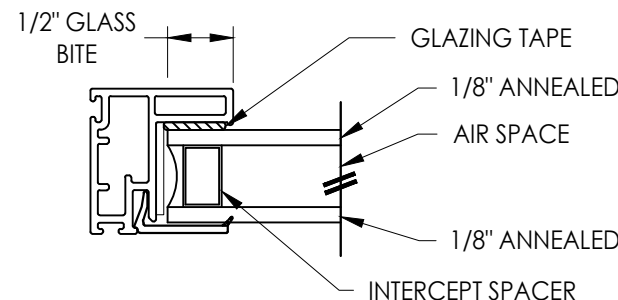

**G2 GLAZING DETAIL**

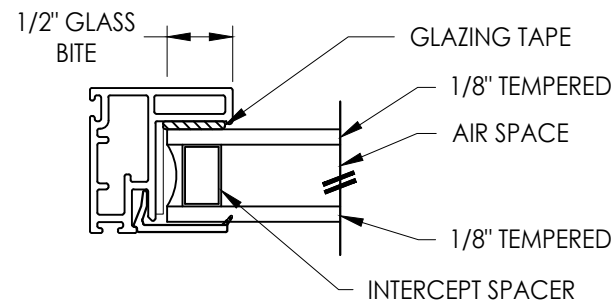

**G3 GLAZING DETAIL**

Documents Prepared By:  
Lyndon F. Schmidt  
P.E. No. 43409

**RW** BUILDING CONSULTANTS, INC.  
P.O. Box 230, Vairico, FL 33595  
Phone No.: 813.659.9197  
FBPE Registry No. 9813

PRODUCT: 500 SERIES Vinyl Single Hung Window  
PART OR ASSEMBLY: BILL OF MATERIALS COMPONENTS & GLAZING DETAILS

NO.	DATE	BY	REVISIONS
4	7/06/23	LFS	UPDATE TO 8TH ED. (2023) FBC
3	7/02/20	LFS	UPDATE TO 7TH ED. (2020) FBC
2	6/01/17	LFS	UPDATE TO 6TH ED. (2017) FBC
1	1/12/16	LFS	ADDED FRAME SIZES

DATE: 2/11/15  
SCALE: N.T.S.  
DWG. BY: JK  
CHK. BY: LFS  
DRAWING NO.: FL-17088.4  
SHEET 5 OF 5